

monitor

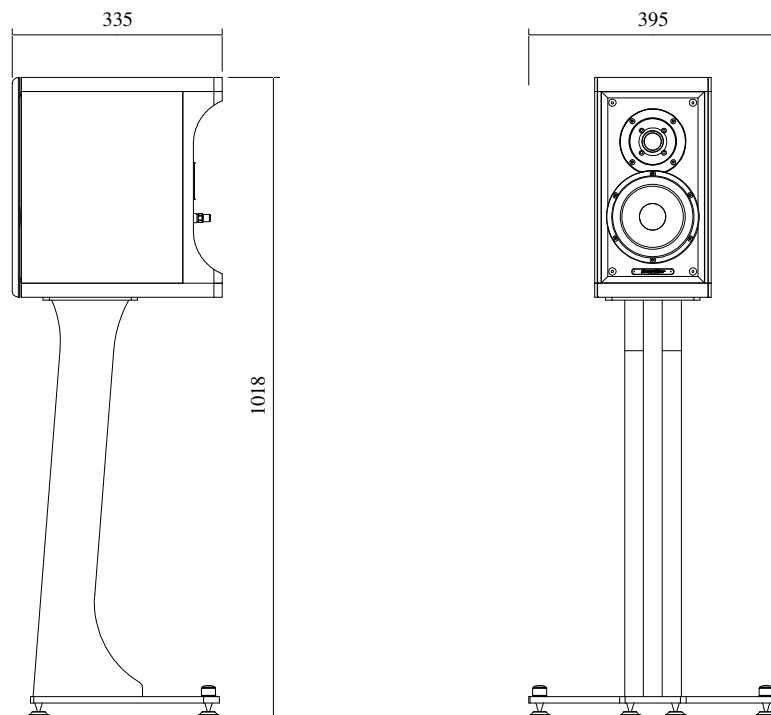

SYSTEM: 2 way vented box loudspeaker.

CABINET: Lute shape design ensures excellent stiffness avoiding resonances and standing waves control.

TWEETER: 25 mm high definition precoated fabric dome driver with a wide, soft polymer surround and a rear chamber. Custom design.

MID-WOOFER: 150 mm cone driver. A free compression basket and a thermo-muldered polypropylene textile cone, also known as “curv”, ensure an excellent dynamic performance. Custom design.

CROSS-OVER: Non-resonant second order design, optimized phase characteristics for optimal space/time performance, cross-over point 3.500 Hz.

FREQUENCY RESPONSE: 55Hz – 25.000 Hz, tuning port included.

SENSITIVITY: 86 dB SPL (2.83 V/1m).

NOMINAL IMPEDANCE: 8 ohm.

POWER HANDLING: 30W – 150 W without clipping.

FINISH: Combination of goffered black and high gloss black piano lacquer.

DIMENSIONS: 350 x 185 x 335 mm (HxWxD).

WEIGHT: 16.5 Kg per pair – net weight / 19.5 Kg per pair – shipping weight.

OPTIONAL DEDICATED STAND: Dimensions: 667 x 395 x 300 mm (HxWxD). Weight: 15.2 Kg per pair – net weight / 18.5 Kg per pair – shipping weight.

TOTAL DIMENSIONS: 1018 x 395 x 335 mm (HxWxD).